

Throttle check valve

Type Z2FS

RE 27518

Edition: 2016-10

Replaces: 10.07



- ▶ Size 10
- ▶ Component series 3X
- ▶ Maximum operating pressure 315 bar [4569 psi]
- ▶ Maximum flow 160 l/min [42.3 US gpm]

Features

- ▶ Sandwich plate valve
- ▶ Porting pattern according to ISO 4401-05-04-0-05, NFPA T3.5.1 R2 and ANSI B93-7D05
- ▶ For the main or pilot flow limitation of 2 actuator ports.
- ▶ 3 adjustment types, optional:
 - Lockable rotary knob with scale
 - Spindle with internal hexagon and scale
 - Rotary knob with scale
- ▶ For supply or discharge throttling
- ▶ Corrosion-protected design

Contents

Features	1
Ordering code	2
Symbols	3
Function, section	4
Technical data	5
Characteristic curves	6
Dimensions	7 ... 10
Further information	10

Ordering code

01	02	03	04	05	06	07	08	09	10
Z2FS	10			- 3X	/				*

01	Twin throttle check valve, sandwich plate design	Z2FS
02	Size 10	10
03	Throttle check valve side A and B	- 1)
	Throttle check valve side A	A
	Throttle check valve side B	B

Adjustment type

04	Lockable rotary knob with scale	3 ²⁾
	Spindle with internal hexagon and scale	5
	Rotary knob with scale	7
05	Component series 30 ... 39 (30 ... 39: unchanged installation and connection dimensions)	3X
06	With two throttle check valves, supply or discharge throttling (the valve can be rotated)	no code
	Supply throttling on side A (version "A...S")	S
	Supply throttling on side B (version "B...S")	
	Discharge throttling on side A (version "A...S2")	S2
	Discharge throttling on side B (version "B...S2")	

Corrosion resistance

07	None	no code
	Improved corrosion protection (240 h salt spray test according to EN ISO 9227); (only version "5" without scale)	J3

Seal material

08	NBR seals	no code
	FKM seals	V
	Observe compatibility of seals with hydraulic fluid used. (Other seals upon request)	

Pilot oil duct

09	None	no code
	Via channel X and Y	SO30
10	Further details in the plain text	

¹⁾ Identical adjustment types on sides A and B

²⁾ H-key with material no. **R900008158** is included in the scope of delivery.

**Notes:**

Preferred types and standard units are specified in the EPS (standard price list).

Symbols (① = component side, ② = plate side)

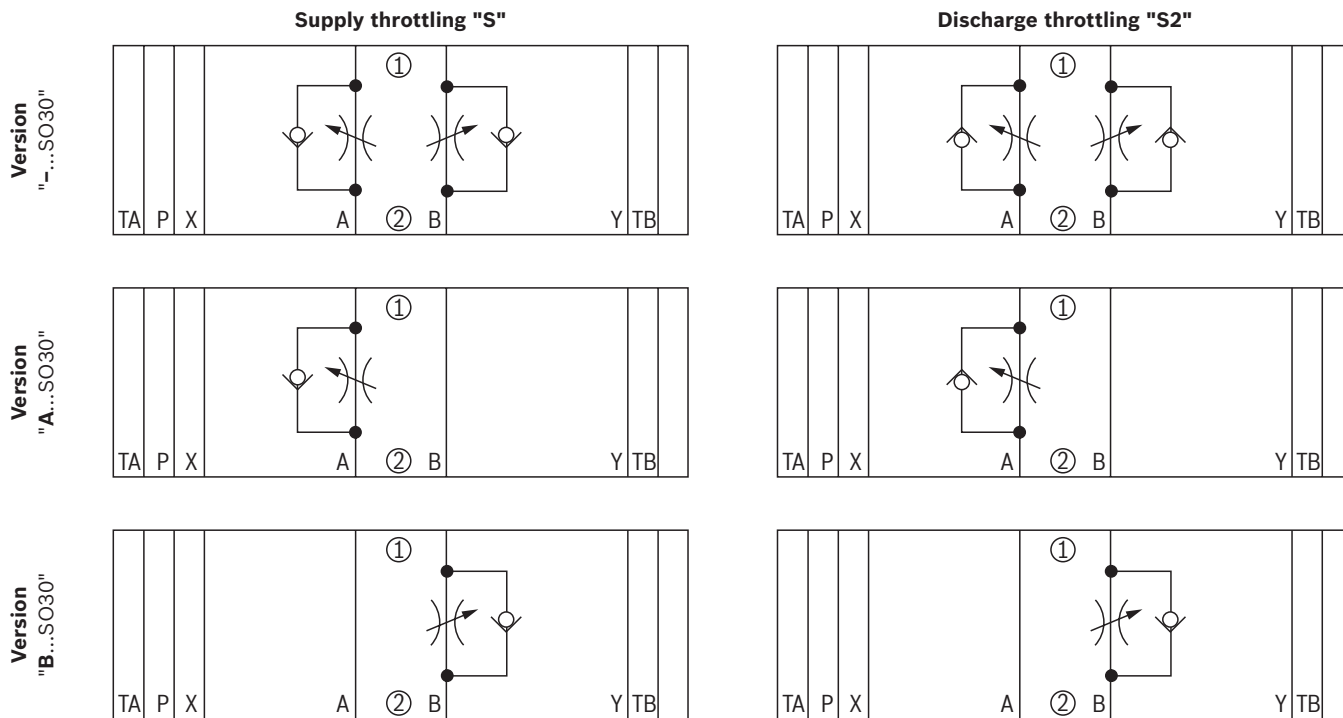

Notice:

- ▶ Deviating from ISO 4401, port T is called TA and port T1 is called TB in this data sheet.
- ▶ Version "SO30" is shown. The standard version does not have ports X and Y.

Function, section

The valve type Z2FS 10 is a throttle check valve in sandwich plate design. It is used for the main or pilot flow limitation of one or two actuator ports.

Two throttle check valves aligned symmetrically to each other limit flows in one direction and allow free return flow in the opposite direction.

In case of supply throttling, the hydraulic fluid is directed through channel A1 via throttling point (1) formed by the control edge (2) and the throttle spool (3.1) to actuator A2. The throttle spool (3.1) can be axially adjusted via the spindle (4) for adjustment of the throttling point (1).

Simultaneously, the hydraulic fluid in channel A1 is directed via the bore (5) to the piston side (6). The active pressure and the spring force retain the throttle spool (3.1) in throttle position.

The hydraulic fluid return flow from actuator B2 displaces the throttle spool (3.2) against the spring (7) and enables the unobstructed flow as check valve. Depending on the installation position, the throttling effect may occur in supply or discharge.

Main flow limitation

For actuator velocity adjustment (main flow limitation), the throttle check valve is installed between the directional valve and the subplate.

Pilot flow limitation

With pilot-operated directional valves, the throttle check valve can be applied for switching time adjustment (pilot flow limitation). In this case, it is installed between the pilot control valve and the main valve.

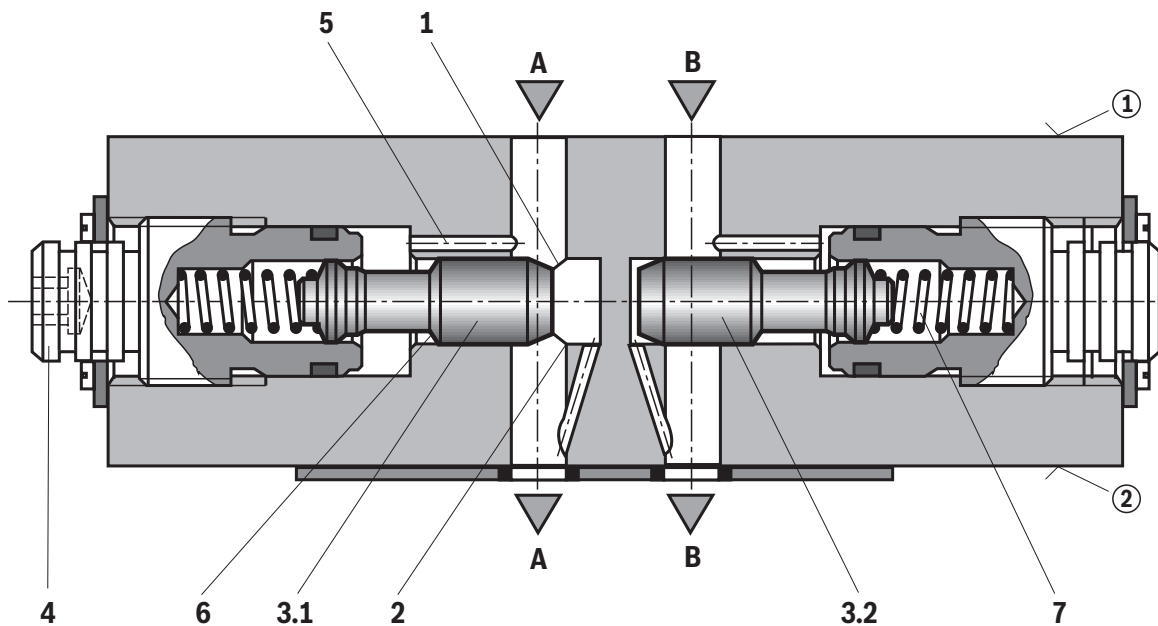

Supply throttling

Technical data

(For applications outside these parameters, please consult us!)

general		
Weight	kg [lbs]	Approx. 3.1 [6.8]
Installation position		Any
Ambient temperature range	°C [°F]	-30 ... -80 [-22 ... -176] (NBR seals) -20 ... +80 [-4 ... +176] (FKM seals)

hydraulic		
Maximum operating pressure	bar [psi]	315 [4569]
Maximum flow	l/min [USgpm]	160 [42.2]
Hydraulic fluid		See table below
Hydraulic fluid temperature range	°C [°F]	-30 ... -80 [-22 ... -176] (NBR seals) -20 ... +80 [-4 ... +176] (FKM seals)
Viscosity range	mm ² /s [SUS]	10 ... 800 [60 ... 3710]
Maximum admissible degree of contamination of the hydraulic fluid Cleanliness class according to ISO 4406 (c)		Class 20/18/15 ¹⁾

Hydraulic fluid	Classification	Suitable sealing materials	Standards	Data sheet
Mineral oils	HL, HLP	NBR, FKM	DIN 51524	90220
Bio-degradable ²⁾	▶ Insoluble in water	HETG	ISO 15380	90221
		HEES		
	▶ Soluble in water	HEPG	ISO 15380	
Flame-resistant	▶ Water-free	HFDU (glycol base)	ISO 12922	90222
		HFDU (ester base) ²⁾		
	▶ Containing water	HFC (Fuchs Hydrotherm 46M, Petrofer Ultra Safe 620)	NBR	ISO 12922



Important information on hydraulic fluids:

- ▶ For more information and data on the use of other hydraulic fluids, please refer to the data sheets above or contact us.
 - ▶ There may be limitations regarding the technical valve data (temperature, pressure range, life cycle, maintenance intervals, etc.).
 - ▶ The ignition temperature of the hydraulic fluid used must be 50 K higher than the maximum surface temperature.
- ▶ **Flame-resistant – containing water:**
 - Maximum pressure differential 210 bar, otherwise, increased cavitation erosion
 - Life cycle as compared to operation with mineral oil HL, HLP 30 ... 100%
 - Maximum hydraulic fluid temperature 60 °C
 - ▶ **Bio-degradable and flame-resistant:** If this hydraulic fluid is used, small amounts of dissolved zinc may get into the hydraulic system.

Characteristic curves

(measured with HLP46, $\vartheta_{oil} = 40 \pm 5 \text{ }^\circ\text{C}$ [$104 \pm 9 \text{ }^\circ\text{F}$])

Δp - q_v characteristic curves (via check valve)

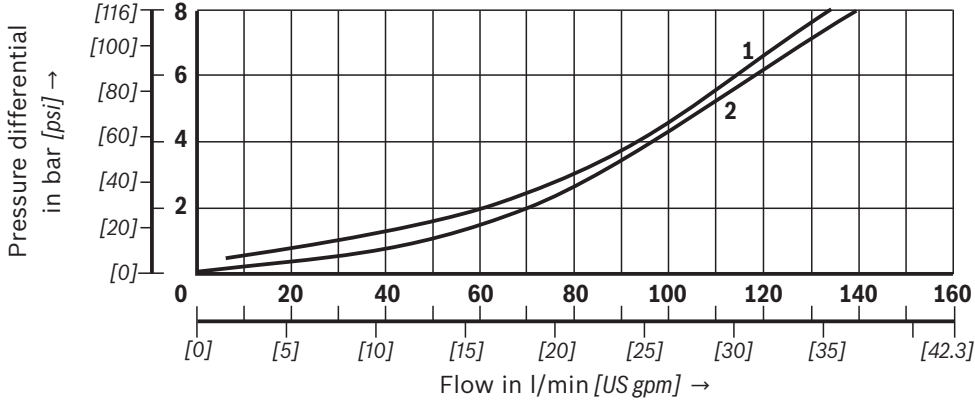

- 1 Throttle closed
- 2 Throttle open

Δp - q_v characteristic curves (throttle position constant)

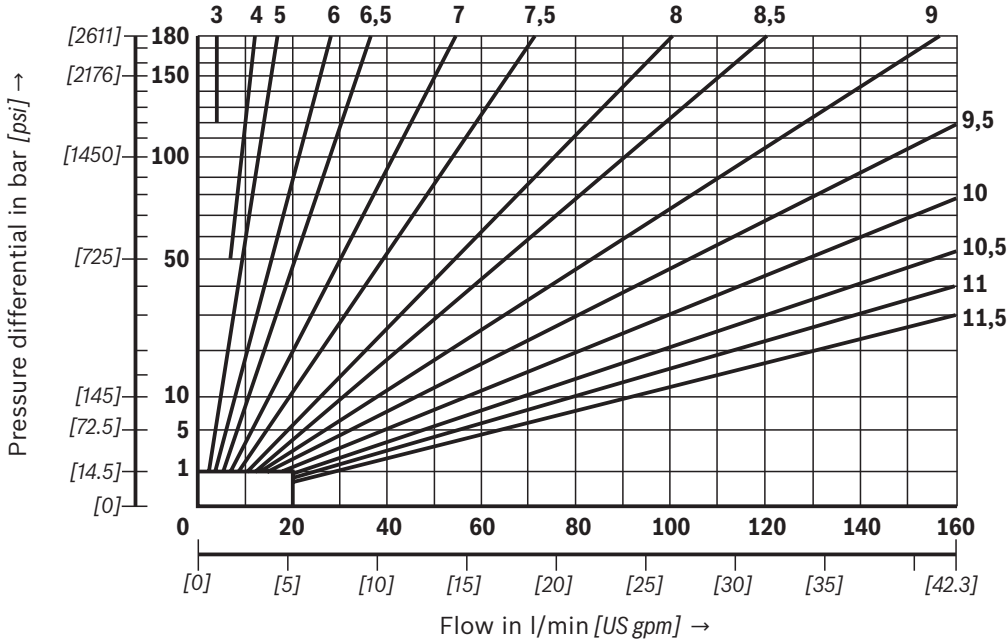

Throttle position in rotations

Dimensions: Version "-"
(dimensions in mm [inch])

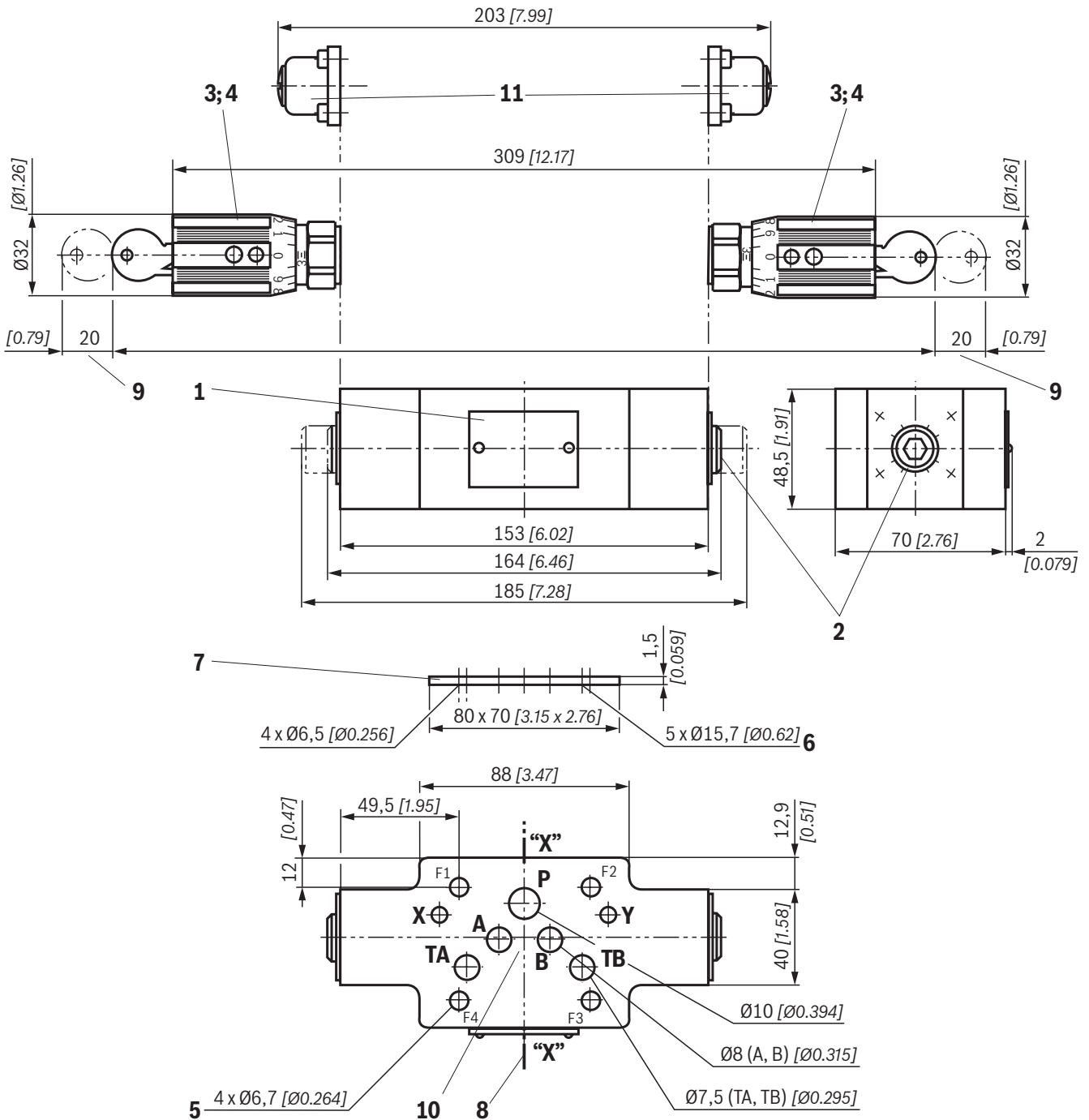

Notes:

- ▶ Deviating from ISO 4401, port T is called TA and port T1 is called TB in this data sheet.
- ▶ The dimensions are nominal dimensions which are subject to tolerances.
- ▶ Version "SO30" is shown. The standard version does not have ports X and Y.

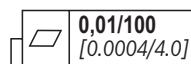

Rzmax 4

Required surface quality of the valve contact surface

Item explanations and valve mounting screws
see page 10.

Dimensions: Version "A"
(dimensions in mm [inch])

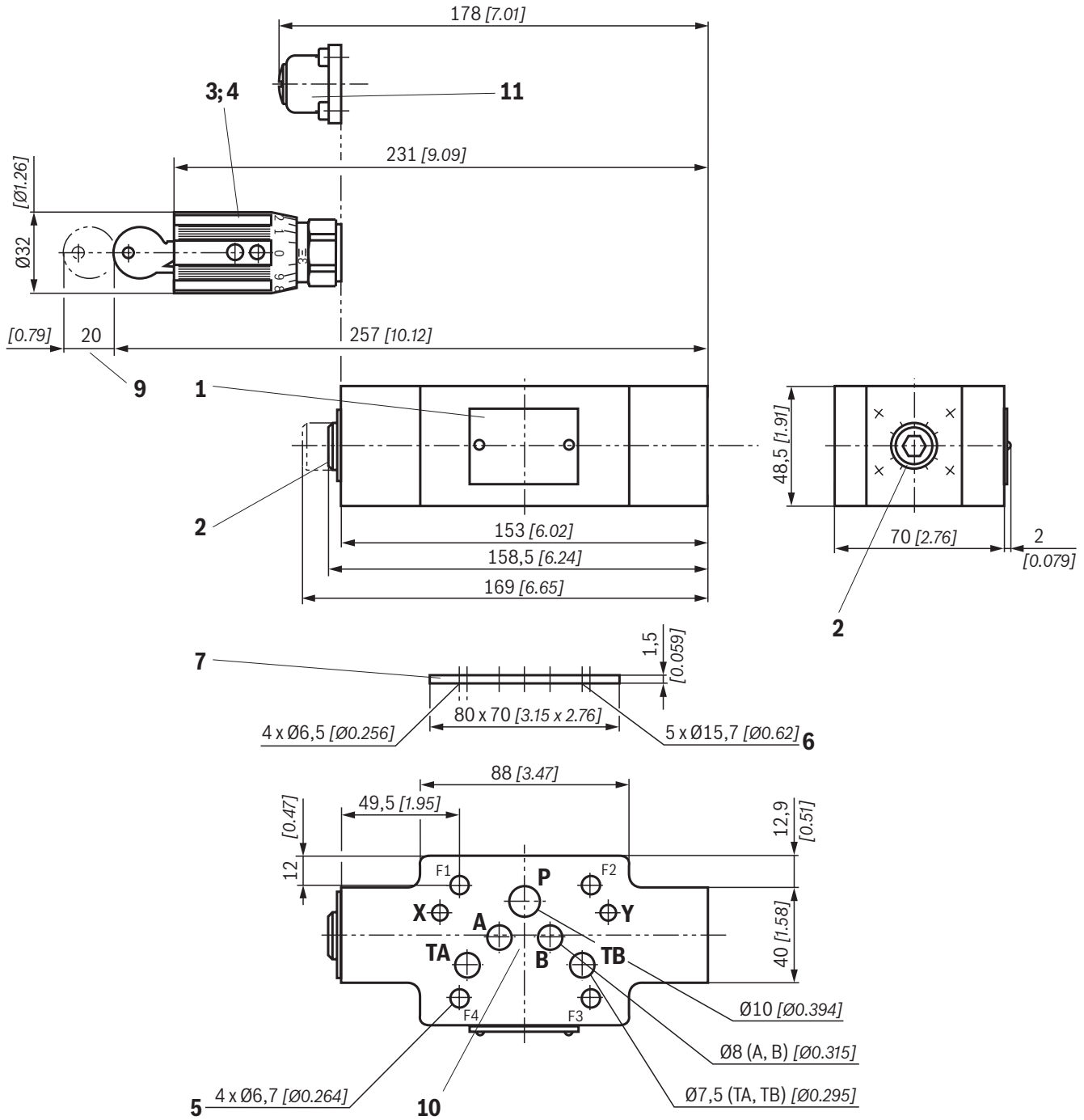

Notes:

- ▶ Deviating from ISO 4401, port T is called TA and port T1 is called TB in this data sheet.
- ▶ The dimensions are nominal dimensions which are subject to tolerances.
- ▶ Version "SO30" is shown. The standard version does not have ports X and Y.

\square 0,01/100
[0.0004/4.0]

\surd Rzmax 4

Required surface quality of the valve contact surface

Item explanations and valve mounting screws

see page 10.

Dimensions: Version "B"
(dimensions in mm [inch])

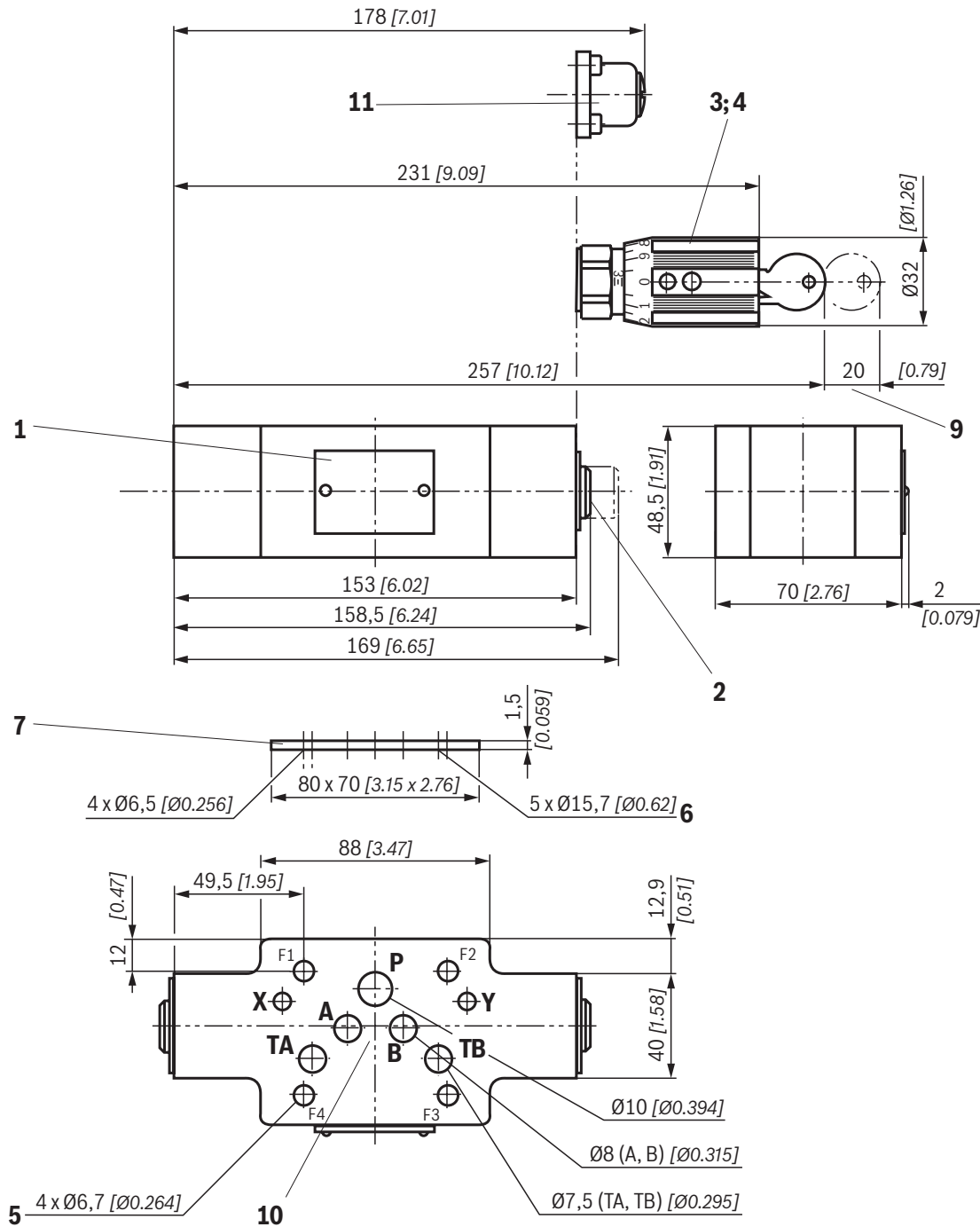

Notes:

- ▶ Deviating from ISO 4401, port T is called TA and port T1 is called TB in this data sheet.
- ▶ The dimensions are nominal dimensions which are subject to tolerances.
- ▶ Version "SO30" is shown. The standard version does not have ports X and Y.

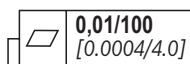

Rzmax 4

Required surface quality of the valve contact surface

Item explanations and valve mounting screws

see page 10.